



INVITATION FOR BIDS

1. The Chairman, RDA Procurement Committee invites sealed bids from eligible and qualified bidders for the contract described below:-

Contract No	Contract Name	Engineer's Estimate including contingencies w/o Vat (Mn)	Bid Security (Rs.)	Contract Period (Days)	Eligibility	Pre-Bid Meeting
RDA/DPR/NCP/KKHB/2020/ 147	Construction of balance work of bridge across Kala Oya at Kagama, Helabodugama Road at Kagama, Bulnawa (Proposed Bridge details Deck - 3.5m x 72m, Retaining wall- 40 m, Approach road both sides 60m)	49.00	400,000	183	CIDA C-5 & C-4 In Bridge speciality (Only for regional contractors)	10.30 a.m. on 30-11-2020 Provincial Director's Office (NCP) Anuradhapura Site Visit arrange after the meeting
RDA/DPR/UP/DKKMB/2020/ 148	Construction of Bridge across Dhahamal Oya on Kehelkotuwa-Kalugahawadiya Road at Kehelkotuwa, Medgama, Bibile	35.00	300,000	546	CIDA C-5 & C-4 In Bridge speciality (Only for regional contractors)	10.30 a.m. on 30-11-2020 Provincial Director's Office (Uva) Bandarawela Site Visit arrange after the meeting

2. The work consists of repair works of Bridge on substructures, super structure & approach roads.
3. Bidding will be conducted through the National Competitive Bidding Procedure.
4. Bidding Documents may be inspected & downloaded for Bid Submission free of charge at web site of Road Development Authority (<http://www.rda.gov.lk/source/publications.htm>)
5. Bidding Documents in English language shall be purchased by interested bidders on submission of a Scanned Copies of written application and a Pay Order (Validity 90 days) in favour of the "**Director General , Road Development Authority** ", for non refundable fee to email dirprorda@gmail.com of Director (Procurement), Procurement Division, Road Development Authority, 4th Floor, "Maganeguma Mahamedura", DenzilKobbekaduwa Mawatha, Battaramulla **from 23.11.2020 until 07.12.2020 during 09:00 hrs to 15:00 hrs** upon payment of a non refundable fee of Rs 5,000 (without VAT).
6. As per the Public Contract Act No 3 of 1987, the agent and successful winners of the tender shall be registered in the Department of Registrar of Companies.
7. Bid shall be accompanied by a Bid- Security for an amount given in the above table. Bid- Security shall be valid up to 04.05.2021, Bids shall be valid up to 06.04.2021.
8. Scanned copy of completed Bids shall be delivered to E mail: dirprorda@gmail.com to Director Procurement, Road Development Authority, 4th Floor, "Maganeguma Mahamedura", Denzil Kobekaduwa Mawatha, Battaramulla **on or before 14:00 hrs on 08.12.2020**. Late bids will be rejected. Bids will be opened soon after the closing, by using on line Method using the Zoom Meeting Link <https://us05web.zoom.us/j/82810496647?pwd=cGZDWmE5Q01aL0RLTIQ4eFJwenBVQT09>
9. The original copy of the Bid document (Hard Copy) should be handed over to the Reception Counter of the "Maganeguma Mahamedura", Road Development Authority, Denzil Kobbekaduwa Mawatha, Battaramulla , within 03 working days after closing of the bid.
10. For further details, please contact Director Procurement, RDA on Tel: 011-2884790/ E mail: dirprorda@gmail.com

**The Chairman, RDA Procurement Committee, Road Development Authority,
1st floor, "Maganeguma Mahamedura",
No. 216, Denzil Kobbekaduwa Mw, Koswatta, Battaramulla.**

DEMOCRATIC SOCIALIST REPUBLIC OF SRI LANKA

MINISTRY OF HIGHWAYS

BIDDING DOCUMENT FOR

**CONSTRUCTION OF BALANCE WORK OF BRIDGE ACROSS KALA
OYA AT KAGAMA , HELABODUGAMA ROAD AT KAGAMA ,
BULNEWA**

CONTRACT NO. RDA/DPR/NCP/ KKHB/2020/147

ROAD DEVELOPMENT AUTHORITY

NOVEMBER 2020

Table of Content

Project Location Map.....	3
VOLUME 1.....	5
SECTION 1 - Instructions to Bidders.....	6
SECTION 2 - Standard Contract Forms.....	7
FORM OF LETTER OF ACCEPTANCE.....	8
FORM OF PERFORMANCE SECURITY.....	9
FORM OF AGREEMENT.....	10
FORM OF ADVANCE PAYMENT SECURITY.....	11
FORM OF RETENTION MONEY GUARANTEE.....	12
SECTION 3 - Conditions of Contract.....	13
VOLUME 2.....	14
INVITATION FOR BIDS.....	
SECTION 4 - Form of Bid & Qualification Information.....	18
FORM OF BID.....	19
QUALIFICATION INFORMATION.....	20
SECTION 5 - Bidding Data and Contract Data.....	23
BIDDING DATA.....	24
CONTRACT DATA.....	27
SECTION 6 – Specifications.....	31
Standard Specification.....	32
SECTION 7 - Bill of Quantities.....	33
PREAMBLE TO BILL OF QUANTITIES.....	34
SECTION 8 - Drawing.....	
SECTION 9 – Standard Forms.....	47
FORM OF BID SECURITY.....	48
FORM FOR AFFIDAVIT FOR THE CURRENT COMMITMENTS.....	49
FORM FOR THE LETTER FROM THE BANK FOR GRANTING OF A REVOLVING LINE OF CREDIT.....	50

Project Location Map

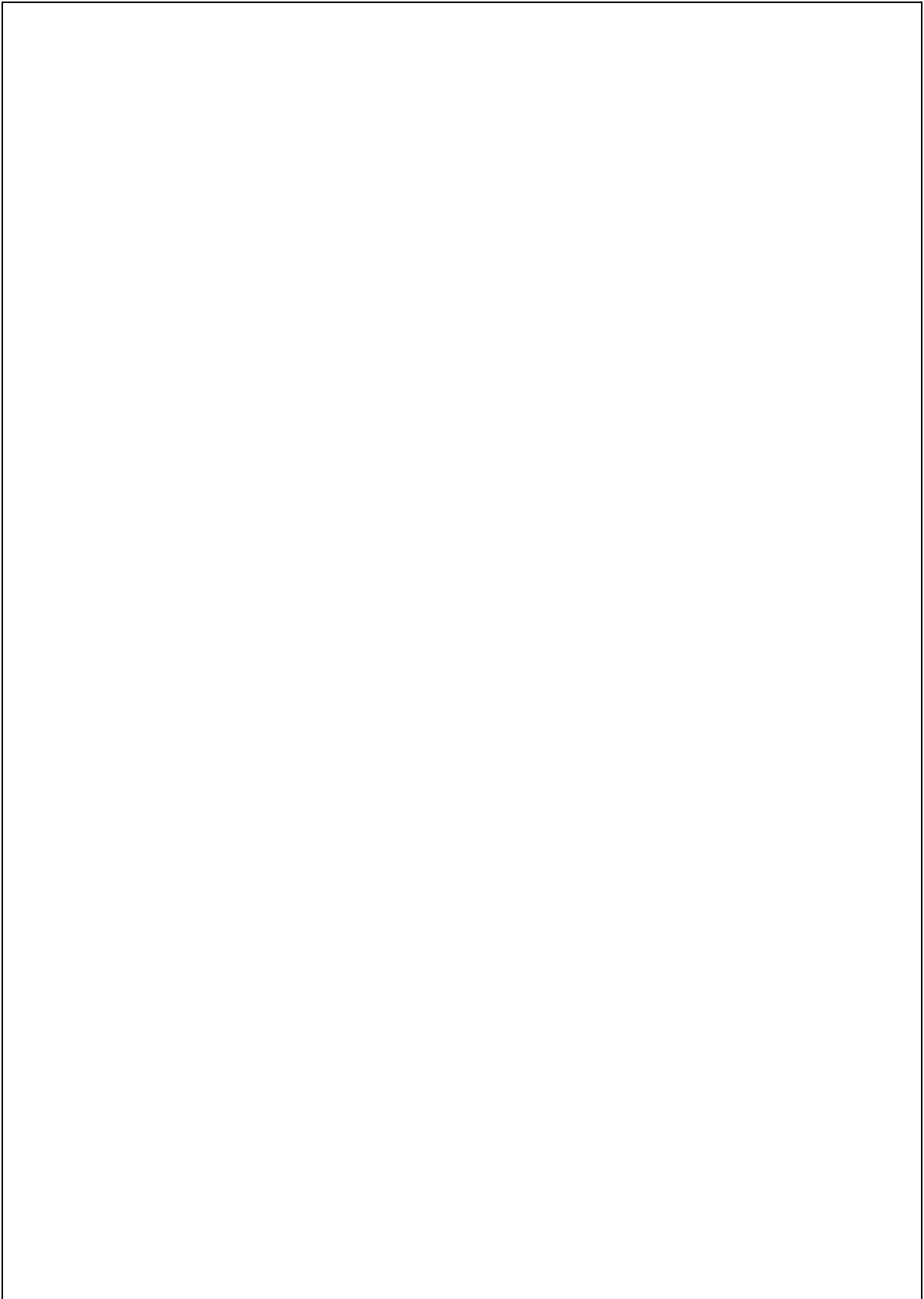

VOLUME 1

VOLUME 1

Section	1	Instruction to Bidders
Section	2	Standard Contract Forms
Section	3	Conditions of Contract

**Please read this in conjunction with Standard Bidding Document for
Procurement of Works (ICTAD/SBD/01 – Second Edition, January 2007)**

SECTION 1 - INSTRUCTIONS TO BIDDERS

Section 1 of Volume 1, ICTAD Standard

Bidding Document

ICTAD publication No. ICTAD/SBD/01 Second Edition

January 2007

SECTION 2 - STANDARD CONTRACT FORMS

- Form of Letter of Acceptance
- Form of Performance Security
- Form of Agreement
- Form of Advance Payment Security
- Form of Retention Money Guarantee

FORM OF LETTER OF ACCEPTANCE

_____ *[Date]*

[Contractor's Name & Address]

This is to notify you that your bid dated for the **CONSTRUCTION OF BALANCE WORK OF BRIDGE ACROSS KALA OYA AT KAGAMA , HELABODUGAMA ROAD AT KAGAMA ,BULNEWA** under Tender No. **RDA/DPR/NCP/KKHB/2020/147** for the Contract Price of Rs.....
.....
..... as corrected in accordance with Instruction to Bidders is hereby accepted.

You are hereby instructed to proceed with the execution of the said Works in accordance with the Contract Documents.

The Contract Number will be **RDA/DPR/NCP/KKHB/2020/147**

The Commencement Date shall be

The amount of Performance Security is.....

The Performance Security shall be submitted on or before

Director General
Road Development Authority

FORM OF PERFORMANCE SECURITY

(Unconditional)

.....
[Issuing Agency's Name, and Address of Issuing Branch or Office]

Beneficiary: Director General, Road Development Authority (hereinafter called and referred to as "the Employer") Maga Neguma Maha medura , Denzil Kobbekaduwa Mawatha, Pelawaththa, Battaramulla.

Date:

PERFORMANCE GUARANTEE No.:

We have been informed that [Name of Contractor]

(Hereinafter called, "the Contractor") has entered into Contract No. **RDA/DPR/NCP/KKHB/2020/147** dated with you, for the **CONSTRUCTION OF BALANCE WORK OF BRIDGE ACROSS KALA OYA AT KAGAMA , HELABODUGAMA ROAD AT KAGAMA ,BULNEWA** , (hereinafter called "the Contract").

Furthermore, we understand that, according to the Conditions of the Contract, a performance guarantee is required.

At the request of the Contractor, we [name of Agency] hereby irrevocably undertake to pay you any sum or sums not exceeding in total an amount of [amount in figures] (.....) [amount in words], upon receipt by us of your first demand in writing accompanied by a written statement stating that the Contractor is in breach of its obligation(s) under the Contract, without your needing to prove or to show grounds for your demand or the sum specified therein.

This guarantee shall expire, no later than the day of2021. [28 days beyond the Intended Completion Date] and any demand for payment under it must be received by us at this office on or before that date.

Signature and the Seal of the Guarantor:.....

Name of the Organization:.....

Address:.....

Date:.....

Witness:.....

FORM OF AGREEMENT

This Agreement made on the [day] of. [month] 2016, between the Road Development Authority established by the Road Development Authority Act No. 73 of 1981 as amended by Act No.37 of 2009, situated at “Sethsiripaya’ Battaramulla, (hereinafter called and referred to as “ the Employer”), of the one part, and.....[name and address of Contractor])(hereinafter called and referred to as “the Contractor”), of the other part:

Whereas the Employer desires that the Contractor executes **CONSTRUCTION OF BALANCE WORK OF BRIDGE ACROSS KALA OYA AT KAGAMA , HELABODUGAMA ROAD AT KAGAMA ,BULNEWA** (hereinafter called and referred to as “the Works”) and the Employer has accepted the Bid by the Contractor for the execution and completion of such Works and remedying of any defects therein.

The employer and the Contractor agree as follows:

1. In this Agreement words and expressions shall have the same meanings as are respectively assigned to them in the Contract.
2. In consideration of the payments to be made by the Employer to the Contractor as indicated in this Agreement, the Contractor hereby covenants with the Employer to execute and complete the Works and remedy any defects therein in conformity in all respects with the provisions of the Contract.
3. The Employer hereby covenants to pay the Contractor in consideration of the execution and completion of the Works and remedying any defects therein, the Contract Price or such other sum as may become payable under the provisions of the Contract at the times and in the manner prescribed by the Contract.

In Witness whereof the parties hereto have caused this Agreement to be executed on the day and year aforementioned in accordance with laws of Sri Lanka.

.....
Authorized Signatory of the Contractor Company Name:.....	Director General Road Development Authority
Common Seal	Common Seal
In the presence of Witness:	In the presence of Witness:
Name.....	Name.....
NIC No.	NIC No.
Address.	Address.

FORM OF ADVANCE PAYMENT SECURITY

.....
[Name and address of Agency, and Address of Issuing Branch or Office]

Beneficiary: Director General, Road Development Authority (hereinafter called and referred to as “the Employer”) Maga Neguma, Maha medura, Battaramulla.

Date:

ADVANCE PAYMENT GUARANTEE No.:.....

We have been informed that [Name of Contractor] (hereinafter called, “the Contractor”) has entered into Contract No. **RDA/DPR/NCP/KKHB/2020/147** dated2020, with you, for the , **CONSTRUCTION OF BALANCE WORK OF BRIDGE ACROSS KALA OYA AT KAGAMA , HELABODUGAMA ROAD AT KAGAMA ,BULNEWA** (hereinafter called “the Contract”).

Furthermore, we understand that, according to the Conditions of the Contract, an advance payment in the sum [Amount in figures] (.....) [Amount in words] is to be made against an advance payment guarantee.

At the request of the Contractor, we [name of issuing Agency] hereby irrevocably undertake to pay you any sum or sums not exceeding in total an amount of[amount in figures] (.....) [amount in words], upon receipt by us of your first demand in writing accompanied by a written statement stating that the Contractor is in breach of its obligation in repayment of the advance payment under the Contract.

The maximum amount of this guarantee shall be progressively reduced by the amount of the advance payment repaid by the Contractor.

This guarantee shall expire on [insert the date, 28 days beyond the Time for Completion]

Consequently, any demand for payment under this guarantee must be received by us at this office on or before that date.

[Signature & Seal of the Organization]

Name of the Organization:.....

Address:.....

Date:.....

Witness:.....

FORM OF RETENTION MONEY GUARANTEE

_____ (Issuing Agency's Name and
Address of Issuing Branch or Office)

Beneficiary: Director General, Road Development Authority (hereinafter called and referred to as "the Employer") Maga Neguma, Mahast floor, Sethsiripaya, Battaramulla.

Date: -----

RETENTION MONEY GUARANTEE No.:-----

We have been informed that ----- (name of Contractor) (hereinafter called "the Contractor") had entered into Contract No. **RDA/DPR/NCP/KKHB/2020/147** dated2020, with you, for the execution of the **CONSTRUCTION OF BALANCE WORK OF BRIDGE ACROSS KALA OYA AT KAGAMA , HELABODUGAMA ROAD AT KAGAMA ,BULNEWA**, (hereinafter called "the Contract")

Furthermore, we understand that, according to the Conditions of Contract, when the works have been taken over and the first half of the Retention Money has been certified for payment, payment of the second half of the Retention Money may be made against a Retention Money guarantee.

At the request of the Contractor, we -----(name of agency) hereby irrevocably undertake to pay you any sum or sums not exceeding in total an amount of ----- (amount in figures)------(amount in words) upon receipt by us of your first demand in writing accompanied by a written statement stating that the Contractor is in breach of its obligation under the Contract because the Contractor has not attended to the defects in accordance with the Contract.

The guarantee shall expire, at the latest, ----- (insert 28 days after the end of the Defects Liability Period). Consequently, any demand for payment under this guarantee must be received by us at this office on or before that date.

(Signature/s)

SECTION 3 - CONDITIONS OF CONTRACT

Section 3 of Volume 1, ICTAD Standard Bidding Document

ICTAD Publication No. ICTAD/SBD/01

Second Edition – January 2007

VOLUME 2

VOLUME 2

- **Invitation For Bids (IFB)**
- **Section 4 Form of Bid & Qualification Information**
- **Section 5 Bidding Data & Contract Data**
- **Section 6 Specifications**
- **Section 7 Bill of Quantities**
- **Section 8 Drawings**
- **Section 9 Standard Forms (Bidding)**

GOVERNMENT OF THE DEMOCRATIC SOCIALIST REPUBLIC OF SRI LANKA

**MINISTRY OF HIGHWAYS
ROAD DEVELOPMENT AUTHORITY**

INVITATION FOR BIDS

1. The Chairman, RDA Procurement Committee invites sealed bids from eligible and qualified bidders for the contract described below:-

Contract No.	Contract Name	Engineer's Estimate including contingencies w/oVat (Mn)	Bid Security (Rs)	Contract Period (Days)	Eligibility	Pre-Bid Meeting
RDA/DPR/NCP/KKHB 2020/ 147	Construction of balance work of bridge across Kala Oya at Kagama, Helabodugama Road at Kagama , Bulnewa (Proposed Bridge details Deck- 3.5mx72m, Retaining wall- 40 m, Approach road both sides 60m)	49.00	400,000	183	CIDA C-5 & C-4 In Bridge speciality (Only for regional contractors)	10.30 a.m. on 30-11-2020 Provincial Director's Office (NCP) Anuradhapura Site Visit arrange after the meeting
RDA/DPR/JP/DKKM 2020/ 148	Construction of Bridge across Dhahamal Oya on Kehelkoduwa-Kalugahawadiya Road at Kehelkoduwa , Medgama , Bibile	35.00	300,000	546	CIDA C-5 & C-4 In Bridge speciality (Only for regional contractors)	10.30 a.m. on 30-11-2020 Provincial Director's Office (Uva) Bandarawela Site Visit arrange after the meeting

2. The work consists of repair works of Bridge on super structure & approach roads.
3. Bidding will be conducted through the National Competitive Bidding Procedure.
4. Bidding Documents may be inspected & downloaded for Bid Submission free of charge at web site of Road Development Authority (<http://www.rda.gov.lk/source/publications.htm>)
5. Bidding Documents in English language shall be purchased by interested bidders on submission of a Scanned Copies of written application and a Pay Order (Validity 90 days) in favour of the " Director General , Road Development Authority ", for non refundable fee to email dirprorda@gmail.com of Director (Procurement) , Procurement Division, Road Development Authority, 4th Floor, "Maganeguma Mahamedura", DenzilKobbekaduwa Mawatha, Battaramulla from 23.11.2020 until 07.12.2020 during 09:00 hrs to 15:00 hrs upon payment of a non refundable fee of Rs 5,000 (without VAT).
6. As per the Public Contract Act No 3 of 1987, the agent and successful winners of the tender shall be registered in the Department of Registrar of Companies
7. Bid shall be accompanied by a Bid- Security for an amount given in the above table. Bid- Security shall be valid up to 04.05.2021, Bids shall be valid up to 06.04.2021
8. Scanned copy of completed Bids shall be delivered to E mail : dirprorda@gmail.com to Director Procurement , Road Development Authority , 4th Floor, "Maganeguma Mahamedura", DenzilKobbekaduwaMawatha, Battaramulla on or before 14:00 hrs on 08.12.2020 .Late bids will be rejected. Bids will be opened soon after the closing, by using On line Method using the Zoom Meeting Link <https://us05web.zoom.us/j/82810496647?pwd=cGZDWmE5Q01aL0RLTIQ4eFJwenBVQT09>

9. The original copy of the Bid document (Hard Copy) should be handed over to the Reception Counter of the Maganeguma Mahamedura", Road Development Authority , Denzil Kobbekaduwa Mawatha, Battaramulla , **within 03 working days** after closing of the bid.

10. For further details, please contact Director Procurement , RDA on Tel : 011-2884790/ E mail : dirprorda@gmail.com

The Chairman,
RDA Procurement Committee
1st Floor, "MaganegumaMahamedura",
Denzil Kobbekaduwa Mawatha,
Battaramulla.

**SECTION 4 - FORM OF BID & QUALIFICATION
INFORMATION**

FORM OF BID

To: The Chairman
RDA Procurement Committee

Bids for the **CONSTRUCTION OF BALANCE WORK OF BRIDGE ACROSS KALA OYA AT KAGAMA , HELABODUGAMA ROAD AT KAGAMA ,BULNEWA** under Contract No: **RDA/DPR/NCP/KKHB/2020/147**

Gentlemen,

1. Having examined the Conditions of Contract given in the Standard Bidding Document - Procurement of Works (ICTAD/SBD/01 - Second Edition January 2007) along with the Contract Data, Specifications, Drawings and Bill of Quantities and addenda Nos..... for the execution of the above-named Works, we the undersigned, offer to execute and complete such Works and remedy any defect therein in conformity with the aforesaid Conditions of Contract, Specifications, Drawings, Bill of Quantities and addenda Nos..... for the sum of Sri Lankan Rupees*.....
.....
.....(SL Rs*.....) or such other sums as may be ascertained in accordance with the said Conditions.
2. We acknowledge that the Bidding Data forms part of our Bid.
3. We undertake to commence the Works as stipulated in the Contract Data, and to complete the whole of the Works comprised in the Contract within the time stated in the Contract Data.
4. We agree to abide by this Bid for the period of 119 days from the time of closing of the Bids or any extended period to which we may agree and it shall remain binding upon us and may be accepted at any time before the expiration of that period.
5. Unless and until a formal Agreement is prepared and executed, this Bid together with your written acceptance thereof shall constitute a binding contract between us.
6. We accept the Adjudicator
7. We understand that you are not bound to accept the lowest or any Bid you may receive.

Dated this day of2020 in the capacity ofduly authorized to sign tenders for and on behalf of.....

Name : (IN BLOCK CAPITALS)

Signature :

Address :
.....

Witness : 1.Name..... Signature

2 Name Signature

**The amount inserted here should not include the VAT component.*

QUALIFICATION INFORMATION

ICTAD Registration	Please attach certified copies of Original Documents as annex
Registration Number	
Grade	
Specialty	
VAT Registration Number	
Construction Program with Resource Allocation	(Attach as annex)
Legal Status	(attach certified copies, as annex)
Authentication of Signatory	(Attach certified copy of Power of Attorney, as annex)
Value of Construction Works Performed	(Attach certified copies of Certificate of Completion etc, as annex)
Year 2019/ Year 2020	
Year 2018	
Year 2017	
Year 2016	
Year 2015	
Value of Similar Works Completed in last 05 years (Indicate only the three largest projects)	1. Value.....Year.....
	2. Value.....Year.....
	3. Value.....Year..... (Attach certified copies of Certificate of Completion etc, as annex)
Major Items of Construction Equipment Proposed Attach list separately	1. Type.....Capacity.....
	2. Type.....Capacity.....
	3. Type.....Capacity.....
	4. Type.....Capacity.....
	5. Type.....Capacity.....
Qualification and Experience of Key Staff – Site & Head Office (Permanent, Contract Basis & Consultants) Attach details of key personal CVs. Separately, proposed to be at site for supervision.	Technical
	1.
	2.
	3.
	Managerial
	1
2	
3	

Details of Sub-Contractors

Section of work	Approximate value	Name(s) & Address(es) of sub-contractors	Description & location of similar works previously executed

Details of Contract Works in Hand

Name of Contract	Value of outstanding work	Estimated completion date

Financial Data

As per Latest Audited Financial Statement

1	Current Assets	
2	Current Liabilities	
3	Working Capital (1-2)	
4	Value of Outstanding Works in Hand	
5	Line of Credit **	
*6	Available Liquid Asset {3 - (0.1) x 4+5}	

*** This amount shall be not less than the amount given in clause 4.4 of ITB**

**** Line of credit if provided shall strictly be as per Form provided in this Document.**

Personnel Data	
Name of Institution	
Address	
Telephone	
Fax mail	
Email address	

Road Development Authority and its authorized representatives are hereby authorized to conduct any inquiries or investigations to verify the statements, documents, and information submitted in this connection and to seek clarification from our banks, any other agency or our clients regarding any financial and technical aspects.

Authorized Signature.....

Date

**SECTION 5 - BIDDING DATA AND
CONTRACT DATA**

BIDDING DATA

A. GENERAL

Clause 1. Scope of Bid

Clause 1.1

a) Employer is the **Road Development Authority established by the Act No.73 of 1981 as amended by Act No.37 of 2009.**

b) Address of the Employer is: *Director General
Road Development Authority
MgaNeguma Mahamedura , Battaramulla
Telephone: 0112862795, Fax: 0112872272
E-mail: gom@rda.gov.lk*

The **Work** consists of Repair works of Bridge on Substructures, Superstructure & approach roads.

The Location of work is at the Maradankadawela at Anuradhapura District.

Clause 1.2

Time for completion is **183 Calendar days** from the Start Date.

Clause 2. Source of Funds

Clause 2.1

Government of Sri Lanka (GOSL) Fund

Clause 4.2

The registration required:

Specialty : **Bridge Construction**
Grade : **C4 & C5**

Clause 4.4

- Average of the annual volume of construction work performed in the last five years shall be at least **Rs140 Mn**
- Minimum Liquidated Assets available shall be **Rs. 24 Mn**
- Similar works completed in last 05 years shall be **Rs 33 Mn**

B. BIDDING DOCUMENTS

Clause 9.1

Employer's address for the purpose of clarification:

Director General , 1st Floor, Maga neguma Mahamedura, Denzil Kobbekaduwa Mawatha, Battaramulla

Tel: 0112862795, Fax: 0112872272

C. PREPARATION OF BID

Clause 11. Language of Bid

Clause 11.1

The language of the Bid shall be English.

Clause 13. Bid Prices

Clause 13.3

VAT component should **NOT** be included in the rates.

Clause 13.4

The Contract is not subjected to price adjustment in accordance with clause 47 of Conditions of Contract.

Clause 14.1

The Currency of bid is **Sri Lankan Rupees (LKR)**

Clause 15. Bid Validity

Clause 15.1

The bid shall be valid for **119 CALENDAR DAYS** from the date of closing of the Bids.

Clause 16 Bid Security

Clause 16.1

Bids shall include a Bid Security using the form included in Section 9

Clause 16.2

Bid Security shall be

- For an amount of **Rs. 400,000.00**
- Valid until **04 th May 2021**
- Issued by Bank operating in Sri Lanka or Construction Guarantee Fund.

Clause 17. Pre-Bid Meeting

Pre-bid meeting:

- Venue : **Office of the Provincial Director, (NCP) Anuradhapura**
- Date : **30 th November 2020**
- Time : **10.30 am.**

Clause 18. Format and Signing of Bid

Add new Sub Clause 18.4

Clause 18.4

All pages of the Bidding documents shall be initialed by the bidder in addition to the signature and official seal on pages explicitly demanded.

D: SUBMISSION OF BID

Clause 19. Sealing and Marking of Bid

Clause 19.2 (a)

The Employer's Address for the purpose of bid submission is -

*Chairman (RDA Procurement Committee)
1 st Floor, Maganeguma Mahamedura
Battaramulla,
Telephone 011-2862795*

Clause 19.2 (b)

The name of the Contract is CONSTRUCTION OF BALANCE WORK OF BRIDGE ACROSS KALA OYA AT KAGAMA , HELABODUGAMA ROAD AT KAGAMA ,BULNEWA

Contract No: **RDA/DPR/NCP/KKHB/2020/147**

Clause 20.1 Deadline for submission of Bid

Scanned copy of completed Bids shall be delivered to E mail : dirprorda@gmail.com to Director Procurement , Road Development Authority, 04 th Floor, Maganeguma Mahamedura , Battaramulla on or before 14:00 hrs on 08th December 2020. Bids will be opened soon after the closing by using On line Method using the Zoom Meeting Link appear in the paper advertisement.

The original copy of the Bid document(Hard Copy) shall be handed over to the Reception Counter of the Maganeguma Mahamedura, Road Development Authority ,Denzil Kobbekaduwa Mawatha, Battaramulla, within 03 working days after closing of the bid.

E. AWARD OF CONTRACT

Clause 34. Performance Security

The amount of Performance Security is **5% (five percent)** of the Initial Contract Price.

Clause 36. Adjudicator

The appointing authority for Adjudicator or Dispute Adjudication Board (DAB) is **the President, Institution of Engineers Sri Lanka.**

CONTRACT DATA

1. Definitions

(1.1) The **Employer** is Road Development Authority established by the Act No 73 of 1981 as amended by Act No.37 of 2009.

Address: Director General, Road Development Authority, 1st Floor, “Sethsiripaya”, Battaramulla.

(1.1) The **Engineer** for the Contract will be appointed by the Chief Engineer-Anuradhapura

(1.1) The **Work** consists of Repair Works of Bridge on Superstructure , Retaining Wall & approach roads.

(1.2) The Location of work is at the **Maradankadawela at Kalawewa in Anuradhapura District.**

(1.1) The start date shall be **14 calendar days** from the date of the Letter of Acceptance.

3. Language and Law

(3.1) The language of the Contract shall be English.

The Contractor shall comply with all applicable national, provincial, and local environmental laws and regulations.

The Contractor shall

- Establish an operational system for managing / minimizing the environmental impacts

- Carry out all of the mitigation measures required during the execution of each construction activity
- Timely submission of reports, information and data to Engineer/ Employer
- Participating in the meetings conveyed by the Engineer
- Any other assistance requested by the Engineer

9. Personnel

(9.1) Schedule of Key Personnel: (Directly involved in the project)

Minimum qualifications and experience for the key personnel is defined as below;

- | | | |
|----|--------------------------|---|
| a. | Project Manager | Civil Engineer with Corporate Membership in an accredited Professional Body (Chartered Engineer). |
| b. | Site Engineer | Engineer or Equally Qualified Personal with three years working experience. |
| c. | Construction Supervision | Technical Officers with min 5 years experience. |

13. Insurance

(13.1) The minimum insurance covers shall be:

- | | |
|----|---|
| a. | The minimum cover for insurance of the Works, Temporary Works and of Plant and Materials is 110% of the Initial Contract Price . |
| c. | The minimum for insurance of other property is Rs. 1 Million per occurrence with the third party, number of occurrences unlimited. |
| d. | The minimum cover for personal injury or death; |
| ▪ | For third party and employees of the Employer and other persons engaged by the Employer is Rs. 550,000/= per event |

(13.2) The minimum cover for personal injury or death shall be:

- For the Contractor's workmen is **Rs. 400,000/= per event**
- Contractor's employees other than workmen is **Rs. 550,000/= per event**

For all the above, the number of occurrence shall unlimited.

The insurance cover shall be valid from **the Start Date to the end of the Defects Liability Period**.

17. The work to be completed by the Intended Completion Date

(17.1) The Intended Completion Date for the whole of Works shall be **183 Calendar days** from the Start Date.

21. Possession of site

(21.1) The Site Possession Date shall be within **03 Calendar days** from the date of Letter of Acceptance.

27. Program

(27.1) The Contractor shall submit a Program with Resource allocation for the Works **along with the priced bid.**

(27.3) The period between Program Update is One month.

35. Correction of Defects

(35.1) The Defects Liability Period is **365 days.**

47 Price Adjustment

Not applicable.

47.1

48. Retention

(48.1) The retention from each payment shall be **10%** percent of the certified work done.

The limit of retention shall be **5 %** of the Initial Contract Price.

49. Liquidated damage

(49.1) The liquidated damages for the whole of the Works shall be **Rs. 24,000.00** per Day.

The maximum amount of Liquidated Damages for the whole of the works shall be **10% (ten percent)** of the Initial Contract Price.

52. Securities

(52.1) The Performance Security shall be **5% (five percent)** of the Initial Contract Price.

58. Operating and Maintenance Manuals

(58.1) Shall be submitted at the time of submission of completion report.

60. Payment upon Termination

60.1 The percentage to apply to the value of the work not completed, representing the Employer's additional cost for completing the Works, is **25%**

63. Provisional Sum and Nominated Sub Contracting

(63)

(63.3) Replace with "**The total sum paid to the Contractor shall include such amounts, for the work, supplies or services plus an Overhead & Profit margin of not more than 20% on the invoiced cost for Provisional Sums of the Bill of Quantities**".

SECTION 6 – SPECIFICATIONS

Standard Specifications

and

Particular Specifications for Preliminaries & General

Standard Specification

Standard Specification for Construction and Maintenance of Roads and Bridges (SSCM of Roads & Bridges) reprinted and issued under the authority of the Director General, Road Development Authority, Second Edition – June 2009 (ICTAD Publication No. SCA/5) are applicable.

SECTION 7 - BILL OF QUANTITIES

Summary of Bill of Quantity

CONSTRUCTION OF BALANCE WORK OF BRIDGE ACROSS KALA OYA AT KAGAMA , HELABODUGAMA ROAD AT KAGAMA ,BULNEWA

1. Bill No 1 - Preliminaries & General
2. Bill No 2 – Super structure & others
3. Bill No 4 - Retaining wall
4. Sub Total A
5. Physical Contingencies (10% of A)
6. Price Contingencies (4 % of A)
6. Sub Total B (without VAT)
7. VAT (08% of B)
8. Total

Amount in Words:(Without VAT) _____

Name of Authorized Officer: _____

Signature: _____

Official Seal

BOQ FOR THE CONSTRUCTION OF BRIDGE BLANCE WORK ESTIMATE BRIDGE ACROSS KALA OYA ON KAGAMA - HELABODUGAMA ROAD AT KAGAMA,BULNEWA

Item No.	Pay Item	Description	Unit	Qty.	Rate	Amount
1.0		Preliminaries and General				
1.1	P(001)	Mobilization and demobilization	Allow	Item	LS	
1.2	103(3)	Allow for barricading , lighting watching traffic safety & control & providing temporary sign boards	Month	6.00		
1.3	P(003)	Provide Furniture & Equipment for Engineer's office	Allow	Item	LS	
1.4	P(004)	Provide Stationary and maintain other services including water, electricity, telephone facilities for the Engineer's office	Allow	Item	PS	150,000.00
1.5	P(005)	Vehicle for the engineer during construction period	Month	6.00		
1.6	P(006)	Office for the EGINEER and Mesurement Assistant	Month	6.00		
1.7	119(1)	Provide contract insurance and securities	Item	Allow	LS	
1.8		Steel Work of placing Girders ,to superstructure and Temporary Road for Internal transport to construction	Item	Allow	PS	200,000.00
Sub Total						

2.0		Packing 50-200mm Dry stone				
2.1.1	ST1-113	Supply & Packing 50-200mm Dry stone lining abutment & Wing wall	Cu.m	92.00		-
2.1.2	T1-007A	Transport of Aggregate 25km	Cu.m.km	2,530.00		-
2.20	ST1-011	Supply & Packing filter medium (75 mm thick aggregate stone layer)	L.m	10.00		-
2.2.1	T1-007A	Transport of Aggregate 25km	Cu.m.km	250.00		-
3.0		Guard stone				
3.1	RF1 - 008	Fixing standard type guard stone.	No	8.00		-
3.2	RF1 - 009	Casting standard type guard stone in concrete 20 (19 mm.)	No	8.00		-
3.3	T1-007A	Transport of Aggregate 25km	Cu.m.km	10.56		-
3.4	T1-007A	Additional T/p of sand 90 km	Cu.m.km	25.06	-	-
4.0		Expansion Joints				
4.1.1	ST1-131	Expansion Joints with M.S angle iron and hard rubber as per drawing	Lm	24.50		
5.0		Bridge Bearing				
5.1.1	ST1-122	Supply & laying approved hard rubber bearing pads 75x12 mm over capping beams	Lm	24.50		-
6.0		Approch fill with Granular material				
6.1		Sub base				
6.1.1	B0 - 201	Supplying of approved soil type -I & II	Cu.m	2,870.00		-
6.1.2	T1-007A	T/p of approved soil type -I & II 30 km	Cu.m.km	86,100.00	-	-
6.1.3		Royalty	Cu.m	2,870.00		-
6.1.4	EW1-006	Approved soil spreading and compaction	Cu.m	2,870.00		-
6.2		Base construction				
6.2.1	M1 - 012A	ABC filling of Base construction	Cu.m	70.00		-
6.2.2	T1-007A	T/p of ABC 25 km	Cu.m.km	1,750.00		-

6.3		Shoulder Construction				
6.3.1	B0-201	Supply approved soil type 1 for Shoulder construction	Cu.m	75.00	-	-
6.3.2		Royalty for above soil	Cu.m	75.00	-	-
6.3.3	T1-007A	Transport of above soil from avg. distance of 40 km	Cu.m.km	2,250.00	-	-
6.3.4	EW1-006	Approved soil spreading & compacting using machinery	Cu.m	75.00		-
6.4		Turf				
6.4.1	DR1-007	Turfing on embankment slopes	Sq.m	456.00		-
6.4.2	DR1-008	Watering & maintaining turf for three months including transport of water	Sq.m	456.00		-
6.4.3	E 1 - 022	Loading Turf	Cu.m	22.80		-
6.4.4	BO-117	Transport above Turf with Tractor&Trailor	Day	3.00		-
6.5		Approch Slab (3m x1m x 0.2m)				
6.5.1	ST1-048	Mixing & Laying Using Concrete Mixture, (W/Batching) cement Concrete Grade 25(19mm) Using crusher run aggregate	Cu.m	4.20		-
6.5.2	T1-007A	Transport of 19mm aggregate in bulk (25km)	Cu.m.km	96.00		-
6.5.3	T1-007A	Additional Transport of sand (90km)	Cu.m.km	227.00		-
6.5.4	ST1-053	Curing of Concrete for 7 days	Sq.m/Day	147.00		-
6.6.1		Reinforcement				
6.6.1a	ST1-055	Fabricate & Tor steel as Reinforcement T12	kg	190.00		-
6.6.1b	ST1-055	Fabricate & Tor steel as Reinforcement T10	kg	9.00	-	-
6.6.1c	ST1-055	Fabricate & Tor steel as Reinforcement R6	kg	1.00	-	-
6.6.2	ST1-063	Form Works for Approach slab	Sq.m	7.00		-
7.0		Construction of Deck				
7.1		Formwork				
7.1.1	ST1-063	Formwork Smooth finished for Deck Concrete	Sq.m	250.00		0.00

7.2		Steel Reinforcement				
7.2.1	ST1-055	Steel Reinforcement (high yield steel for Deck)	kg	5,800.00		0.00
7.3		Deck Concrete grade 40				
7.3.1	ST1-050	Concrete grade 40 (19mm) concrete in deck	Cu.m	51.00		-
7.3.2	T1-007A	Transport of 19mm aggregate in bulk (25km)	Cu.m.km	1,161.00		-
7.3.3	T1-007A	Additional Transport of sand (90 km)	Cu.m.km	2,755.00	-	-
7.3.4	ST1-053	Curing of Concrete for 7 days	Sq.m/Day	1,764.00	-	-
7.3.5	ST1-023	Lifting Concrete	cu.m/Lift	255.00		-
7.4	B0 - 636 B	Forming Rain out holes using 110mm dia PVC pipe (Type 400)	LM	5.40		-
8.0		Passing vehicle park on Deck				
8.1		Safty Standing Pedestrian or Motor bycycle on the Deck widening 05 Location (Traveling time)	Item	Allow	PS	600,000.00
8.2		Wearing Surface				
8.2.1	S1-022	Prime coat using Bitumen Emulsion CSS-1at the rate of 1.0Ltr/Sqm blinding with sand at the250 sq.m/ cu.m and	Sq.m	250.00		
8.2.1a	T1-048	Transport of Emulsion from 220km distance	100L/km	550.00		
8.2.2	S1-015	Tack coat using Emulsion(CSS-1) @ the rate of 0.5 Ltr/Sq.m inclusive of brushing,cleaning road surface and cost of emulsion(mannual)	Sq.m	500.00		
8.2.3	T1-048	Transport of Emulsion from 250 km distance	100L/km	550.00		
8.2.4	S1-033	Supply,lay and compact asphalt concrete cold mix(19mm aggregate,15% cut back 60/70 binder 5.5%) dense(plant made) in small works such as bridge decking	M.Ton	75.00		
8.2.5	T1-009	Transport of cold mix asphalt in bulk from Ganewalpola Plant (20km)	M.Ton/km	1,500.00		
9.0		Steel Work	-			

9.1		Placing 300x300x12mm Thk base plate placing ,Fabricating & fixing steel girders,Brasings,Shear connectors,for deck (Steel girders will be provided by RDA) And Dirusting and painting steel girders with 2coat of anticorrosive paint.	Item	Allow	PS	2,574,000.00
9.2		Supplying ,Fabricating and fixing steel hand rail using 75mm x75mm angle iron uprights 50x50x6mm Iron topping & 37.5mm GI pipes horizontal item rate including apply 2 coats of anti corrosive paint 2nd coat enamel paints.	Lm	172.00		-
10.0		End pillasters				
10.1	ST1-110	End pillasters in Class A concrete of grade 25 (20) with foundation type 1 as per drawing	Nos	4.00		-
10.2	T1-007A	T/p of aggregate 60 km	Cu.m.km	91.00		-
10.3	T1-007A	Additional T/p of sand 90 km	Cu.m.km	216.00		-
11.0		Rip-Rap Construction				
11.1		Filling Rip-Rap				
11.1.1	EW1-013	Supplying and piling Type(i)Sub base Meterials	Cu.m	70.00		-
11.1.2	EW1-007	Spreading and compacting Type(i) Sub base Meterials	Cu.m	70.00		-
11.1.3	T1-007A	Transport of Type(i) Sub base Meterials -30km	Cu.m.km	2,100.00		-
11.1.4		Royalty for Gravel	Cu.m	70.00		-
11.2		Rubble Paving				
11.2.1	P1 - 004	Rubble (Pitched) paving Area (Thick nes - 225mm)	Sq.m	60.00		-
11.2.2	B0-301	Supplying of rubble for rubble paving	Cu.m	9.90		-
11.2.3	T1-007A	Transport of Rubble dis 25 km	Cu.m.km	250.00		-
11.2.4	ST1-015	Grouting Rubble Paving with cement sand mortar	Sq.m	60.00		-
Sub Total						

12.0	Retaning Wall					
12.1	Excavation					
12.1.1	E1-014	Excavation unclassified soil	Cu.m	900.00		0.00
12.2	Scread concrete					
12.2.1	ST1-041	Scread Level Concrete Grade 15 (37.5) for Retining walls	Cu.m	11.50		0.00
12.2.2	T1-007A	Transport of 37.5 mm aggregate from avg. distance	Cu.m.km	287.50		0.00
12.2.3	T1-007A	Additional transport of sand from avg. distance of	Cu.m.km	621.00		0.00
12.3	ST1-055	Fabricate and lay tor steel as reinforcement in Retaning Wall	kg	15,530.00		0.00
12.4	ST1-063	Formwork smooth finish using plywood (shutter 15mm) & class II timber bearers & Joists	Sq.m	420.00		0.00
12.5	G30 Concrete					
12.5.1	ST1-049	Mixing & Laying Using Concrete Mixture, (W/Batching)cement Concrete Grade 30(19mm) Using crusher run aggregate	Cu.m	220.00		-
12.5.2	T1-007A	Transport of 19mm aggregate in bulk 25km	Cu.m.km	5,005.00	-	-
12.5.3	T1-007A	Additional Transport of sand 90 km	Cu.m.km	11,880.00	-	-
12.5.4	ST1-053	Curing of Concrete for 7 days	Sq.m/Day	1,165.50		-
12.6	B0-636B	Forming weepholes using 110mm dia PVC pipe (Type 400)	Meter	36.00	-	-
12.7	Clay puddled					
12.7.1	ST1-012	Clay puddled Laid Behind Walls	Sq.m	40.00		-
12.7.2	T1-007A	Transport of Clay (15km)	Cu.m.km	180.00	-	-
12.8	Packing 50-200m m Dry					

	stone					
12.8.1	ST1-113	Supply & Packing 50-200mm Dry stone lining abutment & Wing wall	Cu.m	160.00		-
12.8.2	T1-007A	Transport of Aggregate 25km	Cu.m.km	4,400.00	-	-
12.9		Construction of necessary coffer dams crib sheeting ,shoring and bracing &subsequent removal	LS			
12.10		Dewatering	LS			
12.11		Back filling				
12.11.1	B0-201	Approved soil excavation for filling behind abutment and wing wall (back filling)	Cu.m	575.00		0.00
12.11.2		Royalty for above soil	Cu.m	575.00		0.00
12.11.3	EW1-006	Approved soil Spreading and compaction behind abutment & wing wall as back filling	Cu.m	575.00		0.00
12.11.4	T1-007A	Transport of above soil from avg. distance of 30 km	Cu.m.km	17,250.00		0.00
Sub Total						

PREAMBLE TO BILL OF QUANTITIES

1. The Bill of Quantities shall be read in conjunction with all other bidding documents.
2. General directions and descriptions of work or materials given elsewhere in the bidding Documents are not necessarily repeated in the Bills of Quantities. For the full meaning of each Item, reference should be made to the applicable passages in the bidding Documents.
3. The prices and rates entered by the Contractor in the Bill of Quantities shall be deemed to cover the complete and finished works in the final position as required by the bidding Documents, including, inter alia, all costs and expenses which may be required in and for the construction and maintenance of the works, together with all risks, liabilities, contingencies, insurance, sampling, testing, providing all necessary assistance to the Engineer and in general all obligations imposed or implied by the contract.
4. Without affecting the generality of the foregoing provisions the prices and rates entered by the contractor in the Bills of Quantities shall also include, inter alia, all costs and expenses involved with or arising from the following:
 - i The provision, storage, transport, handling, use, distribution and maintenance of all materials, plant, equipment, machinery and tools, including all costs, charges, dues demurrage or other outlays involved in carriage and importation.
 - ii The provision and maintenance of all staff and labour and their payment, accommodation, transport, fares and other requirements.
 - iii Setting out, including the location, construction and preservation of survey markers, measurement and supervision.
 - iv The provision, storage, transport, use, handling, distribution and maintenance of all consumable stores fuel, water and electricity including the requirements of the Engineer's Representative and his staff.
 - v The location, test proving, opening, operation, reinstatement of all quarries and borrow pits, as well as compensation and mining royalties costs associated with quarries and borrow pits or any other land the contractor may require additional to that provided free for the execution of the permanent works.
 - vi Sampling, the transport of samples, testing, the carrying out of trial sections of earthworks or payment and the checking of all information given by the Engineer.
 - vii Injury caused to the Works under Construction, Plant, Materials and consumable stores by weather.
 - viii Repairs to the Works either prior to or during the Period of maintenance.
 - ix Maintenance work as detailed in the Specifications and the Conditions of Contract and the maintenance of public amenities.
 - x Co-ordination with other Contractors or Authorities carrying out work either in connection with or adjacent to the Works.

- xi The supply of manufacturers test certificates.
 - xii The protection of mains and services, and cost of repairs in case of damage caused by the Contractor.
 - xiii Pumping and dewatering; the protection of excavation faces.
 - xiv The provision and maintenance of temporary diversions in order that through traffic flow shall remain unobstructed through the contract period and in general the provision of all temporary works required in connection with the works.
 - xv Insurance, custom duties, taxes(excluding VAT) levies, first aid, welfare and safety requirements and all other overheads and costs and profit.
5. A price or rate shall be entered against each Item in the Bills of Quantities whether quantities are stated or not. Item against which no price or rate is entered shall be deemed to be covered by the other prices or rates entered by the Contractor in the Bill of Quantities. The unit price or rate entered against any Item shall take Precedence over any miscalculation in the total sum against that Item. Where separate items have not been provided in the Bill of Quantities for work shall be deemed to have been included in the other prices and rates.
6. The Quantities given in the Bill of Quantities are estimated only and are given to provide a basis for the tender. No guarantee is given for their accuracy and payments to Contractor will be based on the prices and rates quoted in the bills applied to measured quantities for work done.
- The quantity for each Item of work executed by the Contractor in accordance with the Contract shall be measured net and no allowance will be made for waste, bulking, shrinkage decrease of volume due to compaction or the provision of working space.
7. The items in the Bills of Quantities are the general application to the whole of the works at any location on site or any part of the works as indicated in the bid documents or instructed by the Engineer's representative.
8. Tenders, which group several items together in the Bill of Quantities under one price, will not be accepted.
9. The Units of measurement described in the Bill of Quantities are Metric Units. Abbreviations in the Bill of Quantities are as follows: -

Hrs.	-	Hours
km	-	Kilometer
L.m.	-	Linear Metre
m ² or Sq.m.	-	Square Metre
m ³ or Cu.m.	-	Cubic Metre
Nos.	-	Numbers
L.S.	-	Lump Sum
P.S.	-	Provisional Sum
Mth.	-	Month
ltr.	-	Liter
kg.	-	Kilogram
M.T.	-	Metric Ton
mm	-	Millimeter
Wk.	-	Week

DAY WORKS

1. The rates entered in the Schedule for Bill of Quantities shall form day works items for pricing extra work ordered to be done in accordance with the Contract.
2. The rates shall include all overheads and profit and all other costs of whatever nature necessary for and incidental to the performance of extra work whenever ordered and these rates required anywhere on the Site for the operation of plant the provision of labour or the provision of materials and shall be deemed to include inter alia:

Plant Operation, maintenance, repairs, fuel, oils grease, hydraulic fluids, taxes, duties operator's wages and overtime, traveling time, transport supervision, administration costs related to the use of such plant.

Labour Wages, overtime, bonuses, traveling time, hand tools, accommodation, fringe benefits, transport and supervision.

Materials Provision, transport, handling, wastage and storage

In the case of Plant and labour, only time spent working shall be paid for.

For Day works required outside the Site (which for these purposes shall mean all areas shown on the plans for permanent works and all areas of temporary works such as Contractor's and Engineer's camps, quarry, borrow pits and their access roads, diversion roads etc.), the following should be chargeable :

Plant: Self traveling: Actual travel time of and to place of stationing on the day of the work.

Transport: Traveling time of the places of transport (lorry, low loader etc.)

Labour: Travel time for the means of transport used.

Materials: Traveling time for the means of transport used.

The rates shall apply only to such work, as the Engineer shall instruct in writing to be carried out as day works. All items should be priced.

Summary of Bill of Quantity

CONSTRUCTION OF BALANCE WORK OF BRIDGE ACROSS KALA OYA AT KAGAMA , HELABODUGAMA ROAD AT KAGAMA ,BULNEWA

5. Bill No 1 - Preliminaries & General
6. Bill No 2 – Super structure & others
7. Bill No 4 - Retaining wall
8. Sub Total A
5. Physical Contingencies (10% of A)
6. Price Contingencies (4 % of A)
6. Sub Total B (without VAT)
7. VAT (08% of B)
8. Total

Amount in Words:(Without VAT) _____

Name of Authorized Officer: _____

Signature: _____

Official Seal

SECTION 8
DRAWINGS

SECTION 9 – STANDARD FORMS

- 1. Bid Security as per Section 9 of ICTAD/SBD/01**
- 2. Affidavit for the Current Commitments**
- 3. Revolving Line of Credit**

FORM OF BID SECURITY

[This Guarantee form shall be filled in accordance with the instructions indicated in brackets]

..... [insert issuing agency's name, and address of issuing branch or office]

Beneficiary: Director General, Road Development Authority, “Maga Neguma Maha medura”, Denzil Kobbekaduwa Mawatha, Battaramulla.

Date:[insert (by issuing agency) date]

BID GUARANTEE No.:[insert (by issuing agency) number]

We have been informed that[insert (by issuing agency) name of the Bidder] (hereinafter called “the Bidder”) has submitted to you its bid dated [insert (by issuing agency) date] (hereinafter called “the Bid”) for the execution of **CONSTRUCTION OF BALANCE WORK OF BRIDGE ACROSS KALA OYA AT KAGAMA , HELABODUGAMA ROAD AT KAGAMA ,BULNEWA** - Under Contract No: **RDA/DPR/NCP/KKHB/2020 /147**

Furthermore, we understand that, according to your conditions, Bids must be supported by a Bid Guarantee.

At the request of the Bidder, we[insert name of issuing agency] hereby irrevocably undertake to pay you any sum or sums not exceeding in total an amount of[insert amount in figures][insert amount in words] upon receipt by us of your first demand in writing accompanied by a written statement stating that Bidder is in breach of its obligation(s) under the bid conditions, because the Bidder:

- i. has withdrawn its Bid during the period of bid validity specified; or
- ii. does not accept the correction of errors in accordance with the Instruction to Bidders (hereinafter “the ITB”) of the IFB or
- iii. having been notified of the acceptance of its Bid by the Employer during the period of bid validity,
 - (i) fails or refuses to execute the Contract Form, if required, or
 - (ii) fails or refuses to furnish the Performance Security, in accordance with the ITB.

This Guarantee shall expire:

- (a) if the Bidder is the successful bidder, upon our receipt of copies of the Contract signed by the Bidder and of the Performance Security issued to you by the Bidder; or
- (b) if the Bidder is not successful bidder, upon the earlier of the successful bidder furnishing the performance security, otherwise it will remain in force up to(insert date)

Consequently, any demand for payment under this Guarantee must be received by us at the office on or before that date.

Signature and the Seal of the Guarantor:

Name of the Organization

Date:

Witness:

FORM FOR AFFIDAVIT FOR THE CURRENT COMMITMENTS

Director General,
Road Development Authority

In accordance with the Clause 4.2 of the Instructions to Bidders, I (We) declare that the outstanding Contract Commitments of (*Name of the Bidder (s)*) are as follows. I (We) further declare that all the outstanding contract commitments are listed below.

Name of the Contract	Name of the Client	Initial Contract Amount (Rs.)	Outstanding Work (Rs.)

(Add additional tables for Joint Venture Partners.)

.....
Attester

**FORM FOR THE LETTER FROM THE BANK FOR GRANTING
OF A REVOLVING LINE OF CREDIT**

FROM :

.....

.....

TO : Director General
Road Development Authority (RDA)
“Maga neguma - Maha medura”
Denzil Kobbekaduwa Mawatha
Battaramulla
Sri Lanka

SUB : Letter from the bank for providing a line of credit in
Favour of (1) In case of award
to them of works for the Contract of **CONSTRUCTION OF BALANCE
WORK OF BRIDGE ACROSS KALA OYA AT KAGAMA ,
HELABODUGAMA ROAD AT KAGAMA ,BULNEWA**
Contract No. : - **RDA/DPR/NCP/KKHB/2020/147**

Dear Sir,

We (2) bankers of (3)
..... hereby agree to grant revolving line of credit for an
amount of Sri Lanka Rupees for the purpose of the
execution of the Civil Work Contracts under the Contract of
**CONSTRUCTION OF BALANCE WORK OF BRIDGE ACROSS
KALA OYA AT KAGAMA , HELABODUGAMA ROAD AT
KAGAMA ,BULNEW** Contract No:
RDA/DPR/NCP/KKHB/2020/147. This revolving line of credit will be
maintained until the works are taken over by the RDA.

.....
Signature of Representative of the Bank

- (1) Name of Beneficiary / Bidder
- (2) Name of Bank
- (3) Name of Beneficiary / Bidder

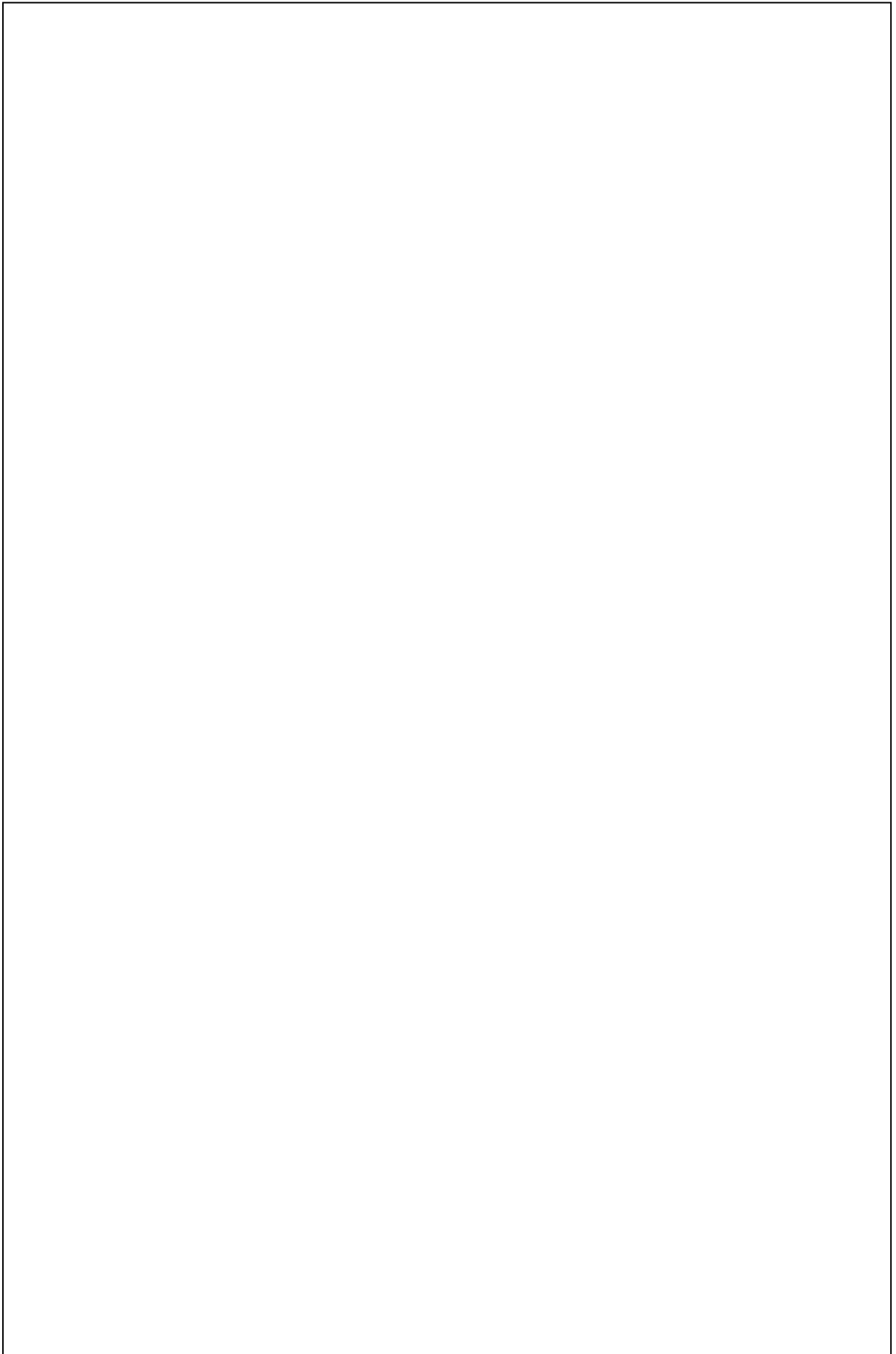

NCP - Bulneue -
Drawing

BACK FILLING ON BRIDGE ACROSS KALAOYA KAGAMA - HELABODUGAMA ROAD

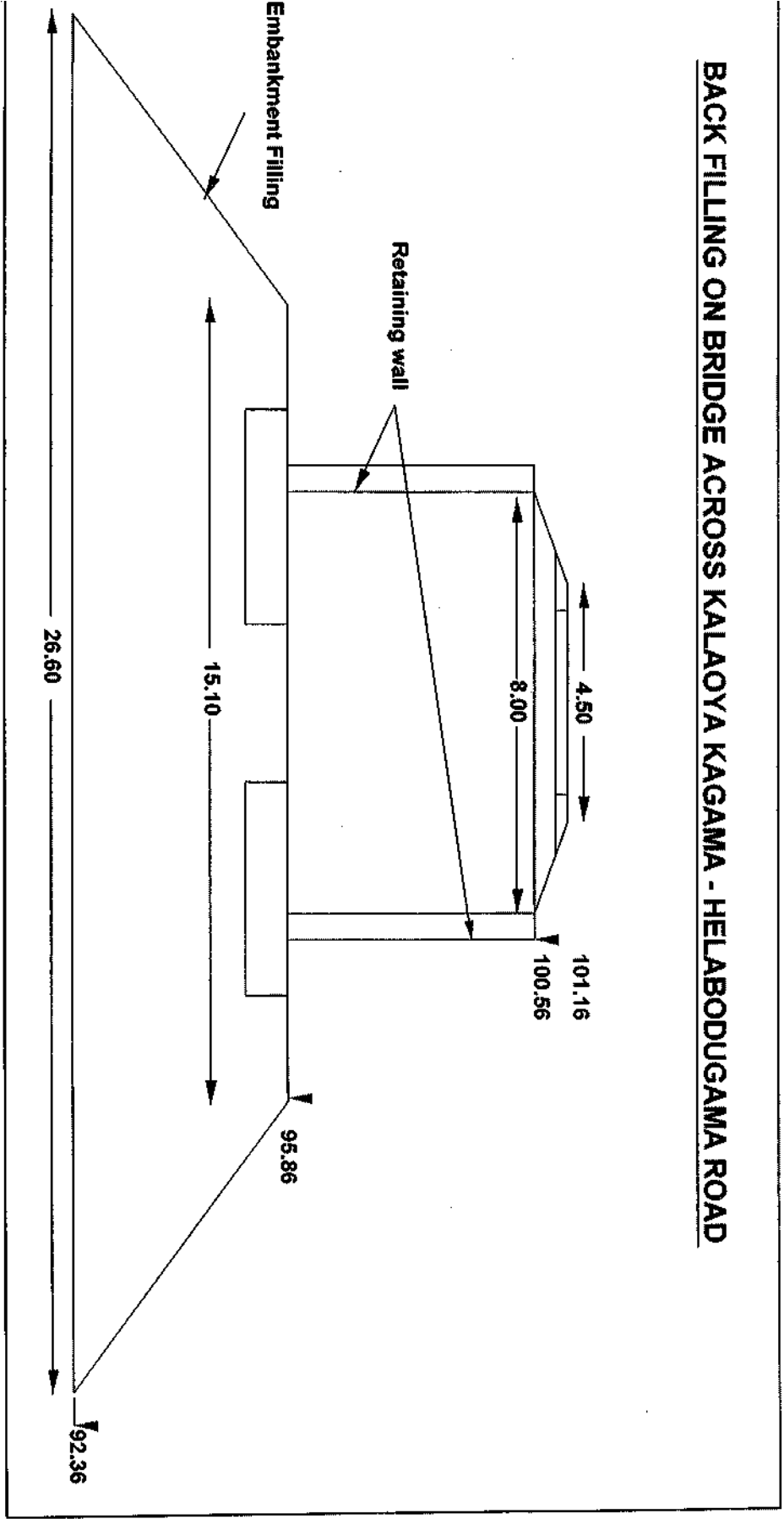

Retaining wall-section 01

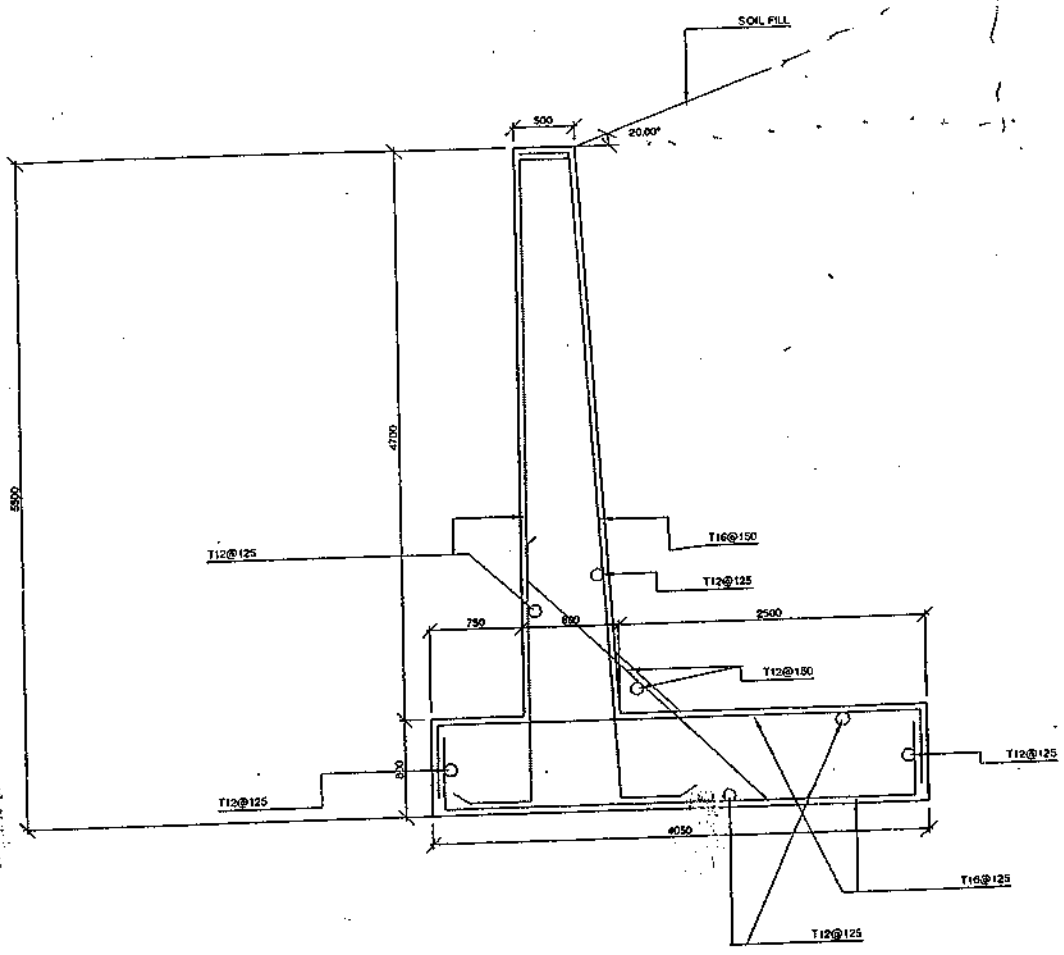

ALLOWABLE BEARING PRESSURE: 250K/M²
BEARING PRESSURE DUE TO WING WALL: 143K/M²
FOS AGAINST SLIDING: 1.92
FOS AGAINST OVERTURNING: 4.5

Retaining wall-section 02

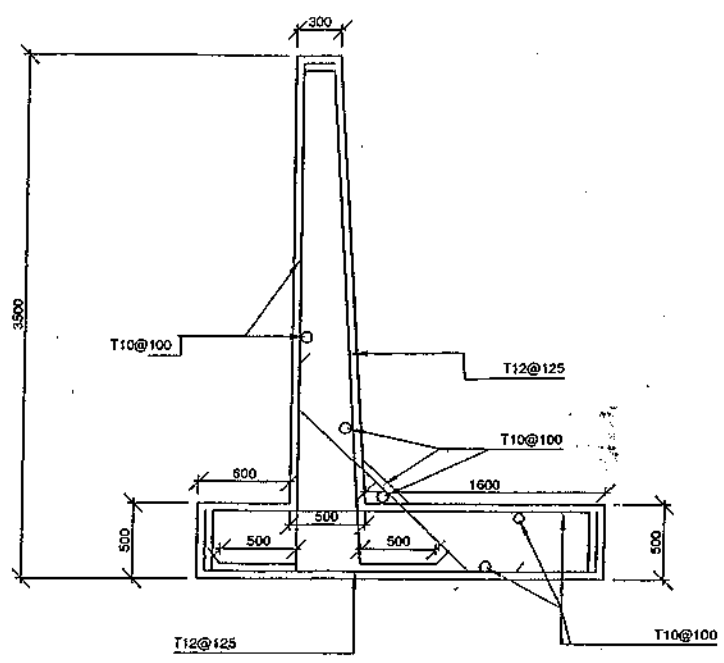

81875
Kegawa Bridge Project
A/E

50 mm ANGLE IRON

3200

75 mm ANGLE IRON
@ 2.50m C/C

T10 - 23-150

T12-22-150

32mm DI. G.I. PIPE

2 T 10-24

T10-25-300

CONC. GRADE

30 (19)

75 mm ANGLE IRON
Brasing @ 2.50m C/C

200

CONC. GRADE

25 (19)

450

867

866

867

450

3500

175 150 850

DETAIL OF DECK